

Entanglement Symmetry of Permutation Symmetric States

Damian Markham

CNRS, LTCI– ENST (Telecom ParisTech), Paris

Motivation

What is the role of entanglement in many-body physics?

Entanglement

Definition:

State is entangled iff NOT separapable

$$\rho_{SEP} = \sum_i p_i \sigma_i^1 \otimes \sigma_i^2 \otimes \dots \otimes \sigma_i^n$$

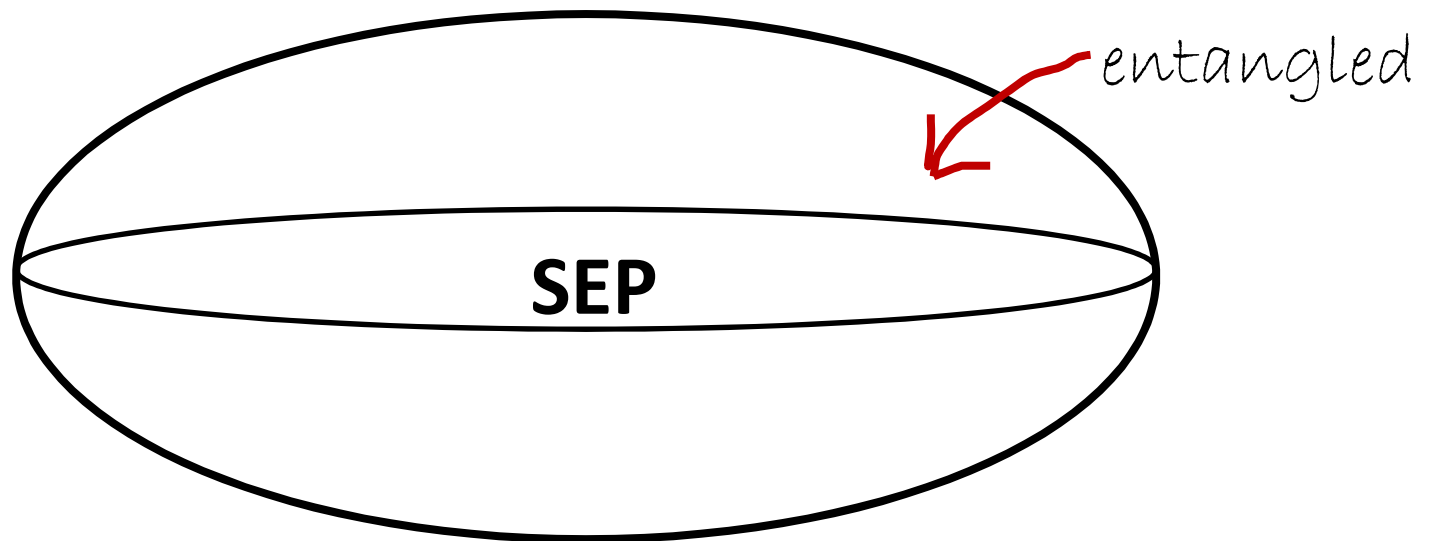

Entanglement

Quantification

Monotone under Local Operations and Classical Communication

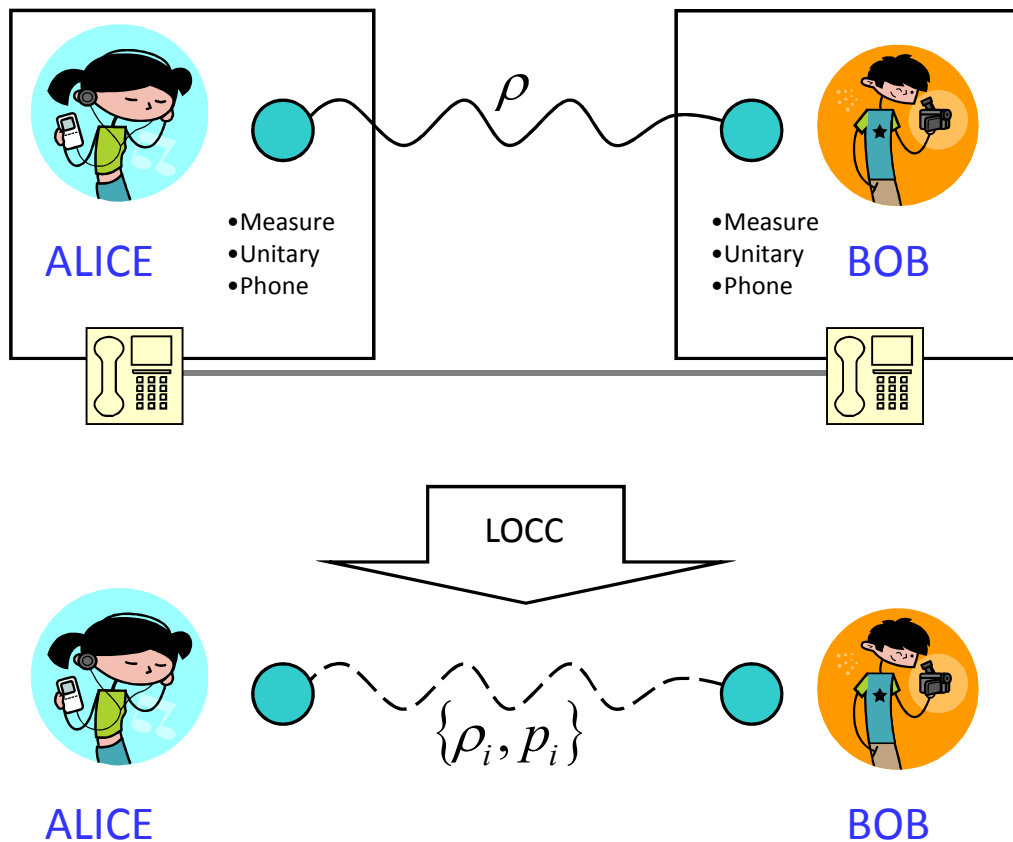

$$\rho \xrightarrow{\text{LOCC}} \{\rho_i, p_i\}$$

$$E(\rho) : \rho \rightarrow \mathbb{R}$$

$$E(\rho) \geq \sum_i p_i E(\rho_i)$$

Any function non-increasing under LOCC

Entanglement

Quantification

Monotone under Local Operations and Classical Communication

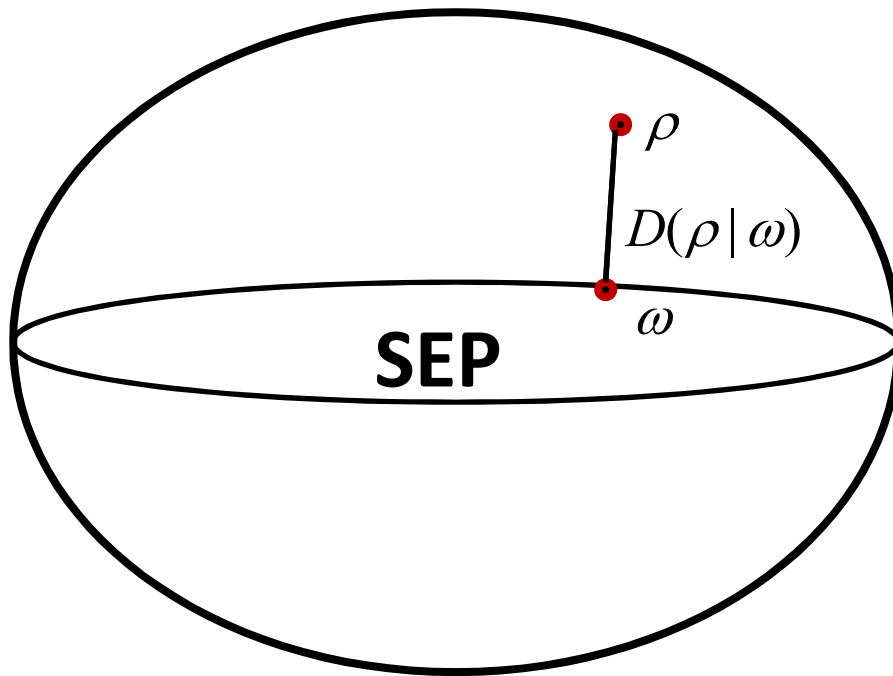

Example:

$$E(\rho) := \min_{\omega \in SEP} D(\rho | \omega)$$

*minimum distance
to separable states*

Entanglement

Types of entanglement

Dur, Vidal, Cirac, PRA 62, 062314 (2000)

In multipartite case, some states are incomparable, even under *stochastic* LOCC (SLOCC)



Infinitely many different classes!

- Different resources for quantum information processing
- Different entanglement measures may apply for different types

Symmetry and Entanglement?

Why should we expect a relationship?

- Symmetry breaking in critical phenomena related to long range correlations – entanglement is most ‘quantum’ correlations
- *We see some !*
 - Change in entanglement properties at critical points in various cases, e.g. In 1D Heisenberg chains
 - A. Osterloh et al Nature 416, 608 (2002)
 - L. Amico et al Rev. Mod. Phys. 80, 517-576 (2008)
- Symmetry a useful tool for entanglement theory

Symmetry and Entanglement?

Next...

- Multiparty entanglement?
- SLOCC classification play any role?
- Deeper connection between symmetry and entanglement?

Look at *symmetry under local unitaries* of
permutation symmetric states

Permutation Symmetric States

Symmetric under permutation of parties

$$|\varphi\rangle \in H^{\otimes n}$$

$$P_{ij}|\varphi\rangle = |\varphi\rangle$$

- Occur as ground states e.g. of some Bose Hubbard models
- Useful in a variety of Quantum Information Processing tasks
- Experimentally accessible in variety of media

Permutation Symmetric States

Majorana representation

E. Majorana, Nuovo Cimento 9, 43 – 50 (1932)

$$|\varphi\rangle = \frac{e^{i\alpha}}{\sqrt{K}} \sum_{Perm} |\eta_1\rangle |\eta_2\rangle \dots |\eta_n\rangle$$

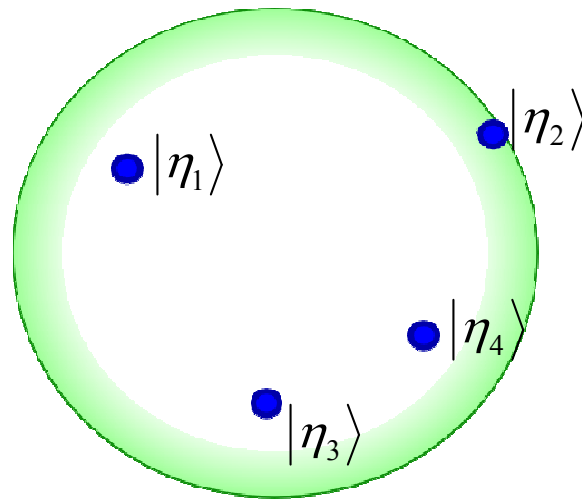

$$|\eta_i\rangle = \cos(\theta_i / 2) |0\rangle + e^{i\phi_i} \sin(\theta_i / 2) |1\rangle$$

Permutation Symmetric States

Majorana representation

E. Majorana, Nuovo Cimento 9, 43 – 50 (1932)

$$|\varphi\rangle = \frac{e^{i\alpha}}{\sqrt{K}} \sum_{Perm} |\eta_1\rangle |\eta_2\rangle \dots |\eta_n\rangle$$

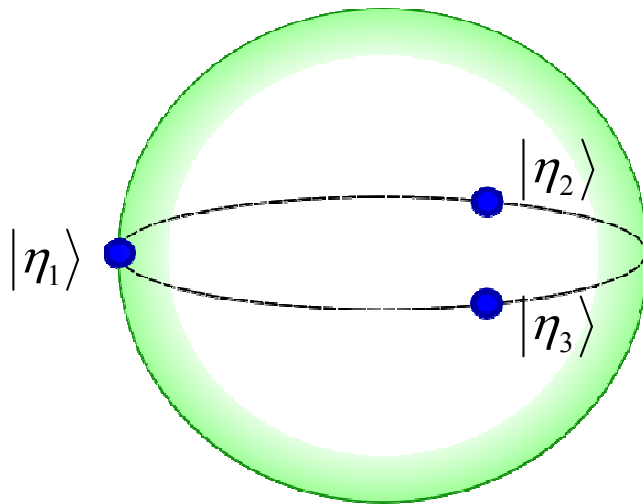

$$\begin{aligned} |GHZ\rangle &= \frac{(|000\rangle + |111\rangle)}{\sqrt{2}} \\ &= 2\sqrt{2} \sum_{Perm} |\eta_1\rangle |\eta_2\rangle |\eta_3\rangle \end{aligned}$$

$$|\eta_1\rangle = 1/\sqrt{2} (|0\rangle + |1\rangle)$$

$$|\eta_2\rangle = 1/\sqrt{2} (|0\rangle + e^{i2\pi/3} |1\rangle)$$

$$|\eta_3\rangle = 1/\sqrt{2} (|0\rangle + e^{i4\pi/3} |1\rangle)$$

Permutation Symmetric States

Majorana representation

E. Majorana, Nuovo Cimento 9, 43 – 50 (1932)

$$|\varphi\rangle = \frac{e^{i\alpha}}{\sqrt{K}} \sum_{Perm} |\eta_1\rangle |\eta_2\rangle \dots |\eta_n\rangle$$

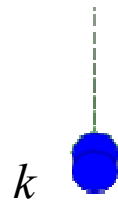
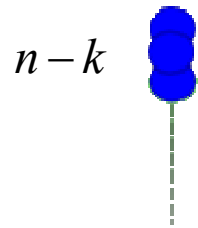

Dicke states

$$|S(n, k)\rangle = \frac{1}{\sqrt{n}} \sum_{PERM} \left| \underbrace{00\dots 0}_{n-k} \underbrace{1\dots 1}_k \right\rangle$$

Permutation Symmetric States

Local Unitary (LU)  Rotation of sphere

$$U \otimes U \dots \otimes U |\varphi\rangle = \frac{e^{i\alpha}}{\sqrt{K}} \sum_{Perm} U |\eta_1\rangle U |\eta_2\rangle \dots U |\eta_n\rangle$$

Symmetries under LU are symmetries of points under SO(3)

- Visualise the geometric measure of entanglement
- LU symmetries imply equivalence of different entanglement measures
- Different symmetries (LU)  different entanglement 'types' (w.r.t. SLOCC)

Geometric Measure of Entanglement

Geometric Measure of Entanglement

- Distance (overlap) to closest product state

$$E_G(|\varphi\rangle) := \min_{\Phi \in \text{prod}} \log_2 \frac{1}{|\langle \varphi | \Phi \rangle|^2}$$

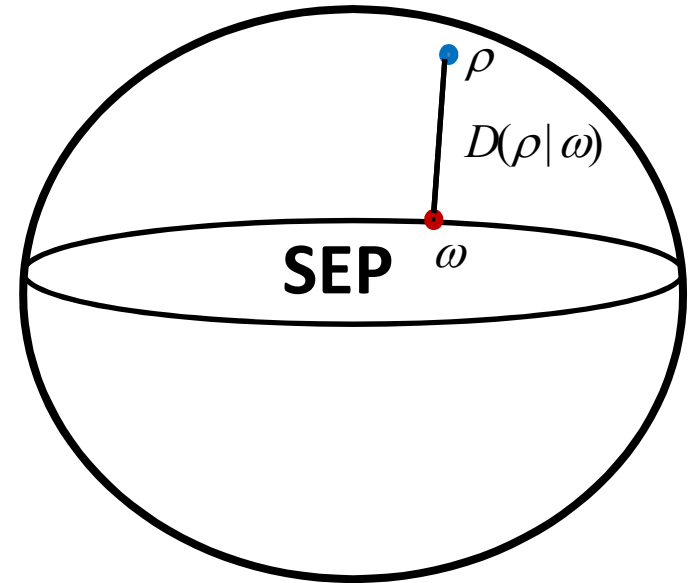

Geometric Measure of Entanglement

- Distance (overlap) to closest product state

$$E_G(|\varphi\rangle) := \log_2 \frac{1}{\Lambda(|\varphi\rangle)}$$

$$\Lambda := \max_{\Phi \in \text{prod}} |\langle \varphi | \Phi \rangle|^2$$

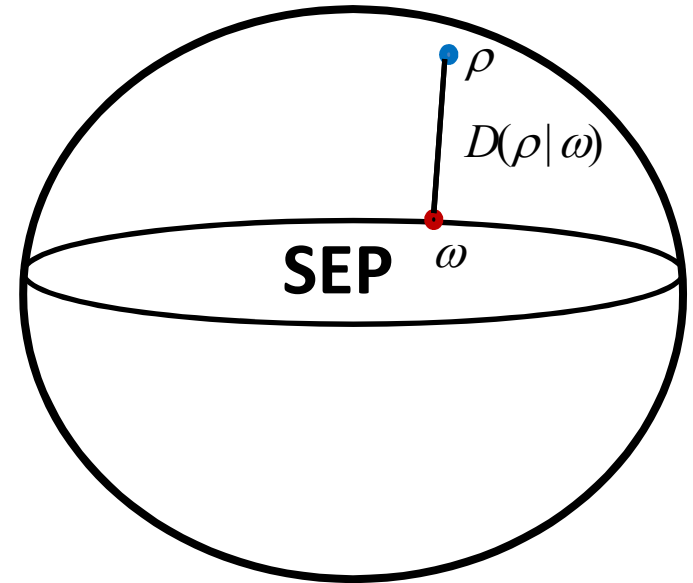

Geometric Measure of Entanglement

- Distance (overlap) to closest product state

$$E_G(|\varphi\rangle) := \log_2 \frac{1}{\Lambda(|\varphi\rangle)}$$

$$\Lambda := \max_{\Phi \in \text{prod}} |\langle \varphi | \Phi \rangle|^2$$

- For $|\varphi\rangle = \frac{e^{i\alpha}}{\sqrt{K}} \sum_{\text{Perm}} |\eta_1\rangle |\eta_2\rangle \dots |\eta_n\rangle$

only need to look for *

$$|\Phi\rangle = |\phi\rangle |\phi\rangle |\phi\rangle \dots |\phi\rangle$$

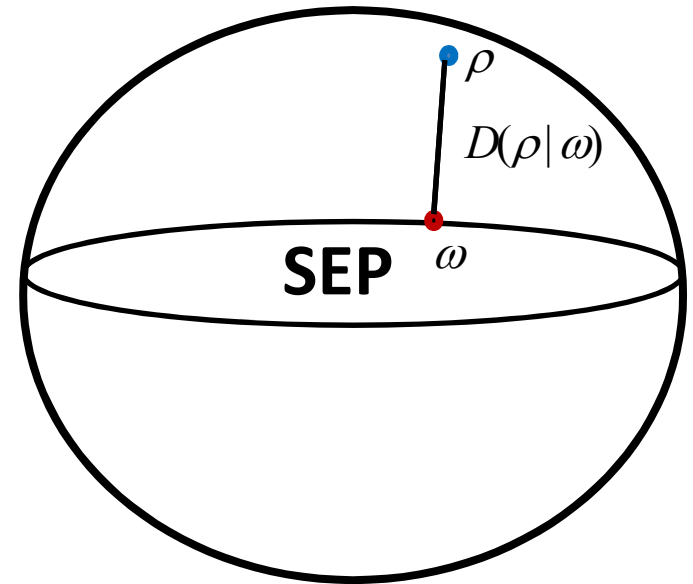

* R. Hubner, M. Kleinmann, T.-C. Wei, C. Gonzalez-Guilln, O. Guhne, PRA 80 032324 (2008)

Geometric Measure of Entanglement

- Distance (overlap) to closest product state

$$E_G(|\phi\rangle) := \log_2 \frac{1}{\Lambda(|\phi\rangle)}$$

$$\Lambda := \max_{\Phi \in \text{prod}} |\langle \phi | \Phi \rangle|^2$$

$$\Lambda_{\text{sym}} = \frac{1}{K} n!^2 \max_{|\phi\rangle} |\langle \eta_1 | \phi \rangle|^2 |\langle \eta_2 | \phi \rangle|^2 \dots |\langle \eta_n | \phi \rangle|^2$$

- For $|\phi\rangle = \frac{e^{i\alpha}}{\sqrt{K}} \sum_{\text{Perm}} |\eta_1\rangle |\eta_2\rangle \dots |\eta_n\rangle$

only need to look for *

$$|\Phi\rangle = |\phi\rangle |\phi\rangle |\phi\rangle \dots |\phi\rangle$$

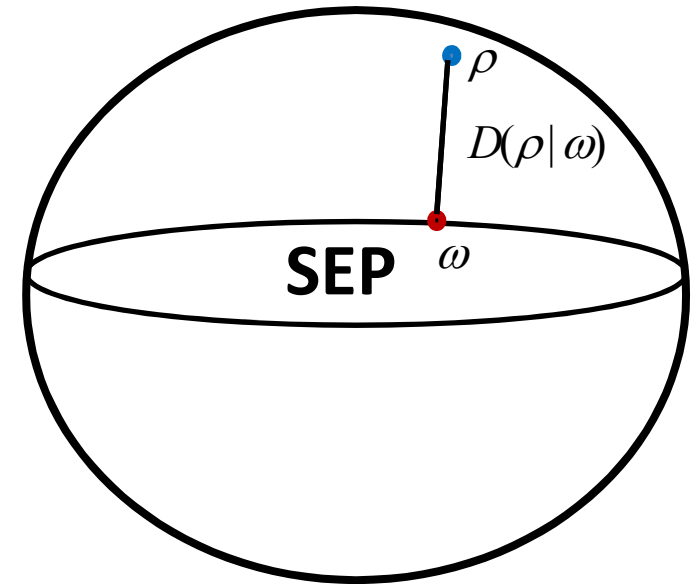

* R. Hubner, M. Kleinmann, T.-C. Wei, C. Gonzalez-Guilln, O. Guhne, PRA 80 032324 (2008)

Geometric Measure of Entanglement

Majorana Representation

- Closest product state is one point ●

$$|\Phi\rangle = |\phi\rangle|\phi\rangle|\phi\rangle \dots |\phi\rangle$$

- Calculating $E_G(|\phi\rangle)$ -> Maximising product of angles

$$E_G(|\phi\rangle) := \log_2 \frac{1}{\Lambda(|\phi\rangle)} \quad \Lambda := \max_{\Phi \in \text{prod}} |\langle \phi | \Phi \rangle|^2$$

$$\Lambda_{\text{sym}} = \frac{1}{K} n!^2 \max_{|\phi\rangle} |\langle \eta_1 | \phi \rangle|^2 |\langle \eta_2 | \phi \rangle|^2 \dots |\langle \eta_n | \phi \rangle|^2$$

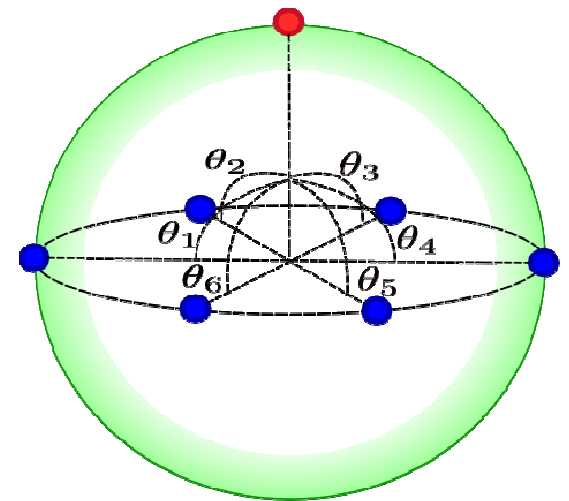

- Symmetry of points helps calculate entanglement

- Most entangled ➡ most 'spread' *

Geometric Measure of Entanglement

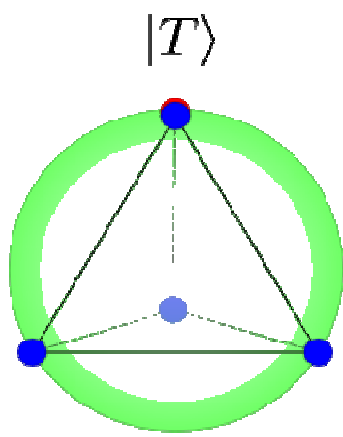

$|T\rangle$

T

$$E = \log(3)$$

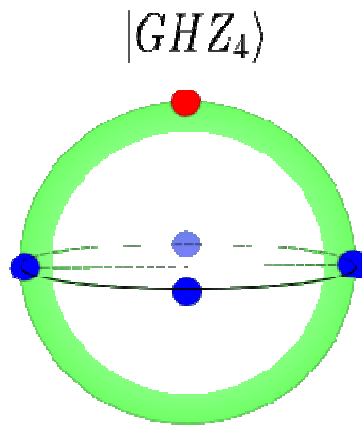

$|GHZ_4\rangle$

D4

$$E = 1$$

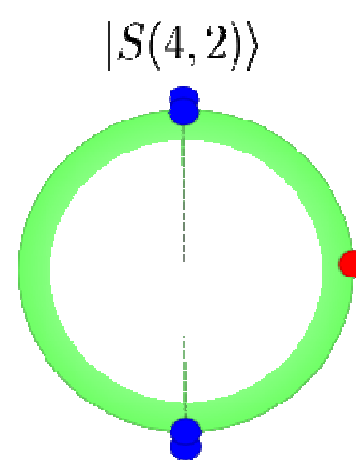

$|S(4,2)\rangle$

O(2)

$$E = \log(8/3)$$

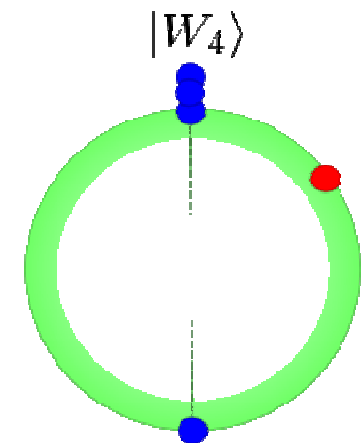

$|W_4\rangle$

SO(2)

$$E = 3\log(4/3)$$

LU symmetry and equivalence of different measures

LU symmetry and equivalence of different measures

- Hierarchy of entanglement measures*

$$r(|\varphi\rangle) \geq E_R(|\varphi\rangle) \geq E_G(|\varphi\rangle)$$

Geometric Measure

$$E_G(|\varphi\rangle) := \min_{\phi \in \text{prod}} \log_2 \frac{1}{|\langle \varphi | \phi \rangle|^2}$$

Relative entropy of entanglement

$$E_R(|\varphi\rangle) := \min_{\omega \in \text{sep}} S(|\varphi\rangle \parallel \omega)$$

$$S(\rho \parallel \omega) := \text{tr}(\rho(\log_2 \rho - \log_2 \omega))$$

Logarithmic Robustness

$$r(|\varphi\rangle) := \log(1 + \min t)$$

$$\text{s.t. } \omega = \frac{1}{(1+t)} (|\varphi\rangle\langle\varphi| + t\Delta) \in \text{sep}$$

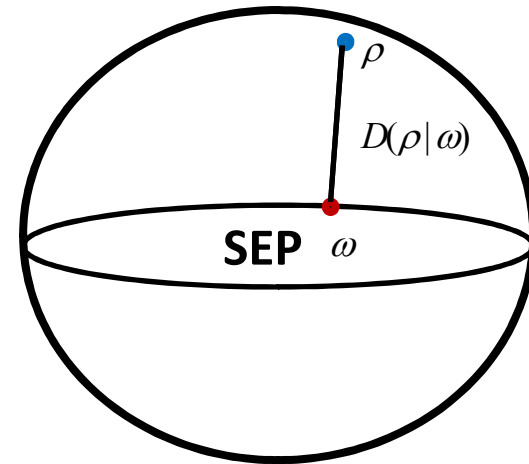

*M. Hayashi, D. Markham, M. Murao, M. Owari and S. Virmani PRL **96** (2006) 040501

LU symmetry and equivalence of different measures

Who cares if these measures are equal?!?

- Different operational meanings

Geometric Measure

$$E_G(|\varphi\rangle) := \min_{\phi \in \text{prod}} \log_2 \frac{1}{|\langle \varphi | \phi \rangle|^2} \quad \text{e.g. Bounds channel capacities}$$

Relative entropy of entanglement

$$E_R(|\varphi\rangle) := \min_{\omega \in \text{sep}} S(|\varphi\rangle \parallel \omega) \quad \text{information theoretic interpretations}$$

$$S(\rho \parallel \omega) := \text{tr}(\rho(\log_2 \rho - \log_2 \omega))$$

Logarithmic Robustness

$$r(|\varphi\rangle) := \log(1 + \min t) \quad \text{robustness of entanglement against noise}$$

$$\text{s.t. } \omega = \frac{1}{(1+t)} (|\varphi\rangle\langle\varphi| + t\Delta) \in \text{sep}$$

- Strategies for LOCC discrimination (access of information) *
- Constuction of optimal entanglement witnesses *

*M. Hayashi, D. Markham, M. Murao, M. Owari and S. Virmani PRA **77** (2008) 012104

LU symmetry and equivalence of different measures

- Hierarchy of entanglement measures

$$r(|\varphi\rangle) \geq E_R(|\varphi\rangle) \geq E_G(|\varphi\rangle)$$

Geometric Measure

$$E_G(|\varphi\rangle) := \min_{\phi \in \text{prod}} \log_2 \frac{1}{|\langle \varphi | \phi \rangle|^2}$$

Relative entropy of entanglement

$$E_R(|\varphi\rangle) := \min_{\omega \in \text{sep}} S(|\varphi\rangle \parallel \omega)$$

$$S(\rho \parallel \omega) := \text{tr}(\rho(\log_2 \rho - \log_2 \omega))$$

Logarithmic Robustness

$$r(|\varphi\rangle) := \log(1 + \min t)$$

$$\text{s.t. } \omega = \frac{1}{(1+t)} (|\varphi\rangle\langle\varphi| + t\Delta) \in \text{sep}$$

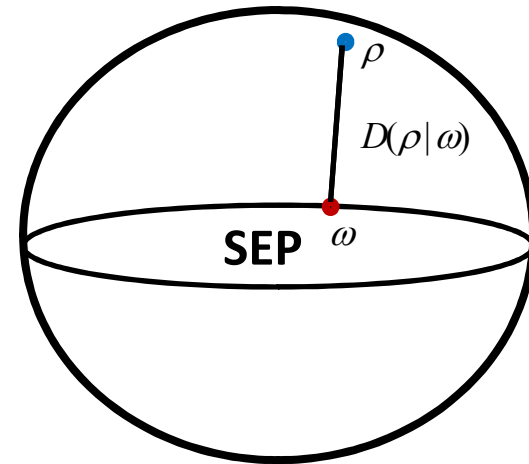

LU symmetry and equivalence of different measures

- Hierarchy of entanglement measures

$$D_r(|\varphi\rangle | \omega') \geq r(|\varphi\rangle) \geq E_R(|\varphi\rangle) \geq E_G(|\varphi\rangle)$$

Geometric Measure

$$E_G(|\varphi\rangle) := \min_{\phi \in \text{prod}} \log_2 \frac{1}{|\langle \varphi | \phi \rangle|^2}$$

Relative entropy of entanglement

$$E_R(|\varphi\rangle) := \min_{\omega \in \text{sep}} S(|\varphi\rangle \| \omega)$$

$$S(\rho \| \omega) := \text{tr}(\rho(\log_2 \rho - \log_2 \omega))$$

Logarithmic Robustness

$$r(|\varphi\rangle) := \log(1 + \min t)$$

$$\text{s.t. } \omega = \frac{1}{(1+t)} (|\varphi\rangle\langle\varphi| + t\Delta) \in \text{sep}$$

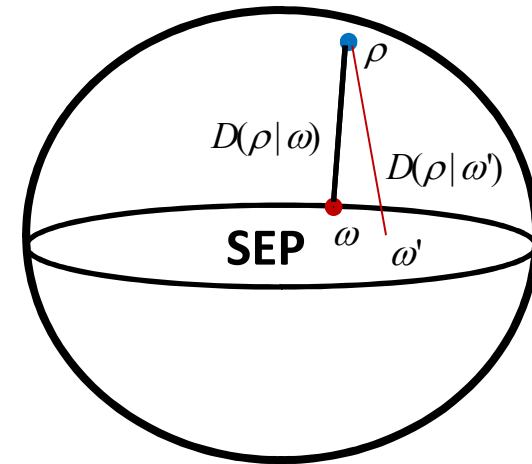

$$\omega' = \frac{1}{(1+t)} (|\varphi\rangle\langle\varphi| + t\Delta) \in \text{sep}$$

$$D_r(|\varphi\rangle | \omega') = \log(1+t)$$

LU symmetry and equivalence of different measures

- Hierarchy of entanglement measures

$$D_r(|\varphi\rangle | \omega') \geq r(|\varphi\rangle) \geq E_R(|\varphi\rangle) \geq E_G(|\varphi\rangle)$$

Geometric Measure

$$E_G(|\varphi\rangle) := \min_{\phi \in \text{prod}} \log_2 \frac{1}{|\langle \varphi | \phi \rangle|^2}$$

Relative entropy of entanglement

$$E_R(|\varphi\rangle) := \min_{\omega \in \text{sep}} S(|\varphi\rangle \| \omega)$$

$$S(\rho \| \omega) := \text{tr}(\rho(\log_2 \rho - \log_2 \omega))$$

Logarithmic Robustness

$$r(|\varphi\rangle) := \log(1 + \min t)$$

$$\text{s.t. } \omega = \frac{1}{(1+t)} (|\varphi\rangle\langle\varphi| + t\Delta) \in \text{sep}$$

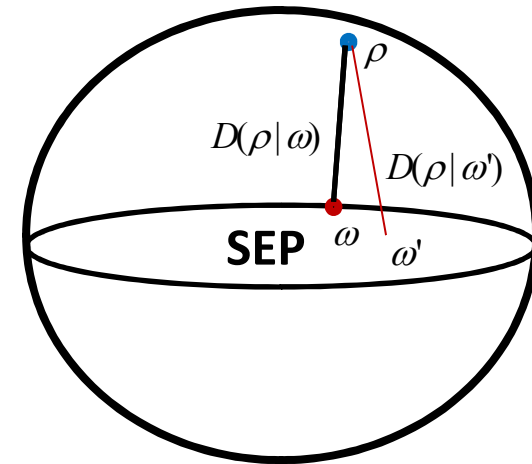

$$\begin{aligned} \omega' &= \frac{1}{(1+t)} (|\varphi\rangle\langle\varphi| + t\Delta) \in \text{sep} \\ D_r(|\varphi\rangle | \omega') &= \log(1+t) \\ &= E_G(|\varphi\rangle) \end{aligned}$$

LU symmetry and equivalence of different measures

- Hierarchy of entanglement measures

$$D_r(|\varphi\rangle | \omega') \geq r(|\varphi\rangle) \geq E_R(|\varphi\rangle) \geq E_G(|\varphi\rangle)$$

- Equality if we can find

$$\omega' = \frac{1}{(1+t)} (|\varphi\rangle\langle\varphi| + t\Delta) \in \text{sep}$$

$$D_r(|\varphi\rangle | \omega') = \log(1+t) = E_G(|\varphi\rangle)$$

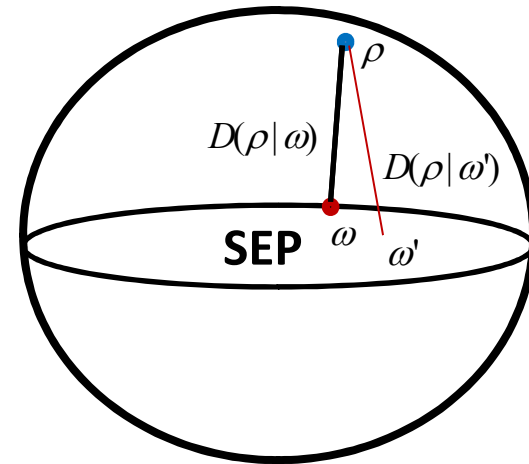

LU symmetry and equivalence of different measures

- ‘Twirl’ over a local group on the solution to the geometric measure

$$\begin{aligned}\omega' &= \int U |\Phi\rangle\langle\Phi| U^\dagger dU \\ &= \sum_i P_i |\Phi\rangle\langle\Phi| P_i\end{aligned}$$

Geometric Measure

$$E_G(|\varphi\rangle) := \min_{\Phi \in \text{prod}} \log_2 \frac{1}{|\langle\Phi|\varphi\rangle|^2}$$

where $U = u \otimes u \otimes \dots \otimes u$ and P_i is projection onto invariant subspace (Shur)

LU symmetry and equivalence of different measures

- ‘Twirl’ over a local group on the solution to the geometric measure

$$\begin{aligned}\omega' &= \int U |\Phi\rangle\langle\Phi| U^\dagger dU \\ &= \sum_i P_i |\Phi\rangle\langle\Phi| P_i\end{aligned}$$

Geometric Measure

$$E_G(|\varphi\rangle) := \min_{\Phi \in \text{prod}} \log_2 \frac{1}{|\langle\Phi|\varphi\rangle|^2}$$

where $U = u \otimes u \otimes \dots \otimes u$ and P_i is projection onto invariant subspace (Shur)

- Thus if $P_1 = |\varphi\rangle\langle\varphi|$

$$\omega' = |\langle\Phi|\varphi\rangle|^2 |\varphi\rangle\langle\varphi| + (1 - |\langle\Phi|\varphi\rangle|^2) \Delta$$

$$\omega' = 2^{-E_G(|\varphi\rangle)} |\varphi\rangle\langle\varphi| + (1 - 2^{-E_G(|\varphi\rangle)}) \Delta$$

$$\omega' = \frac{1}{(1+t)} (|\varphi\rangle\langle\varphi| + t\Delta) \in \text{sep}$$

$$D_r(|\varphi\rangle|\omega') = \log(1+t) = E_G(|\varphi\rangle)$$



LU symmetry and equivalence of different measures

Majorana Representation

If a permutation symmetric state $|\varphi\rangle$ has Majorana Representation which is invariant under some subgroup $X \subset SO(3)$, then this state satisfies

$$r(|\varphi\rangle) = E_R(|\varphi\rangle) = E_G(|\varphi\rangle)$$

- Can systematically check all subgroups of $SO(3)$ to find all such states
 $O(2), SO(2), C_n, D_n, T, O, Y$

LU symmetry and equivalence of different measures

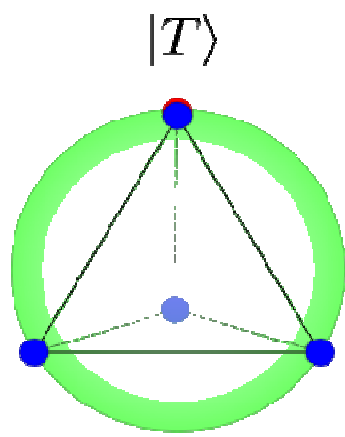

T
 $E = \log(3)$

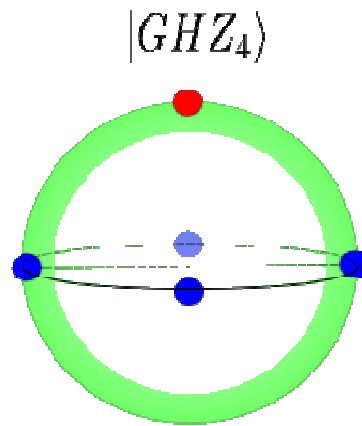

D4
 $E = 1$

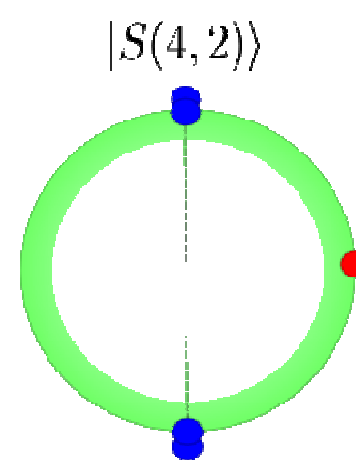

O(2)
 $E = \log(8/3)$

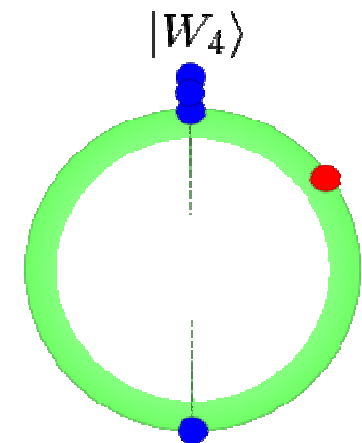

SO(2)
 $E = 3\log(4/3)$

LU Symmetry and Entanglement 'types'

LU Symmetry and Entanglement 'types'

For all n

States of different symmetries

SO(2), D_n, T, O, Y

are SLOCC invertible!

i.e. Different 'types' of entanglement

- Geometric properties of Majorana points underlie SLOCC classes

LU Symmetry and Entanglement 'types'

E.g. $n=4$

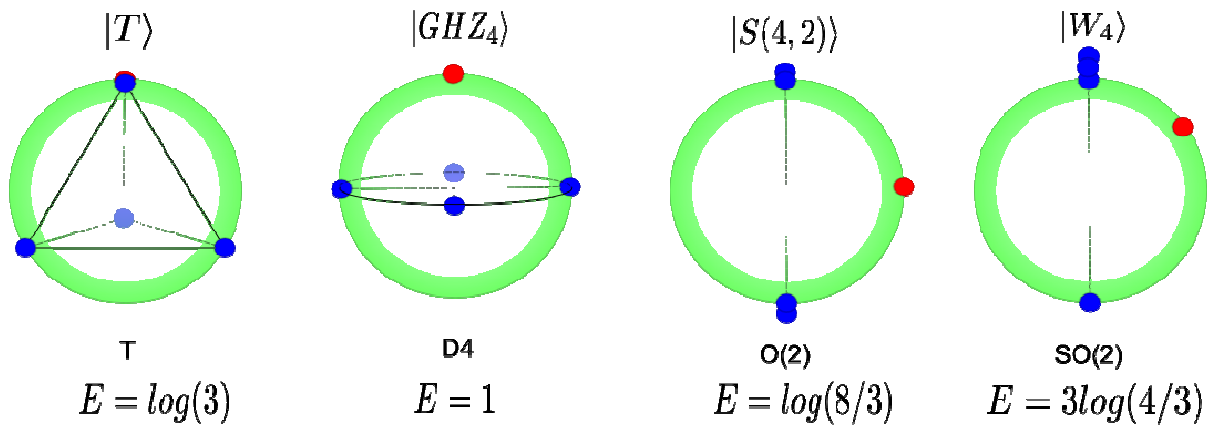

- Multiplicity of points cannot change under SLOCC

LU Symmetry and Entanglement 'types'

E.g. $n=4$

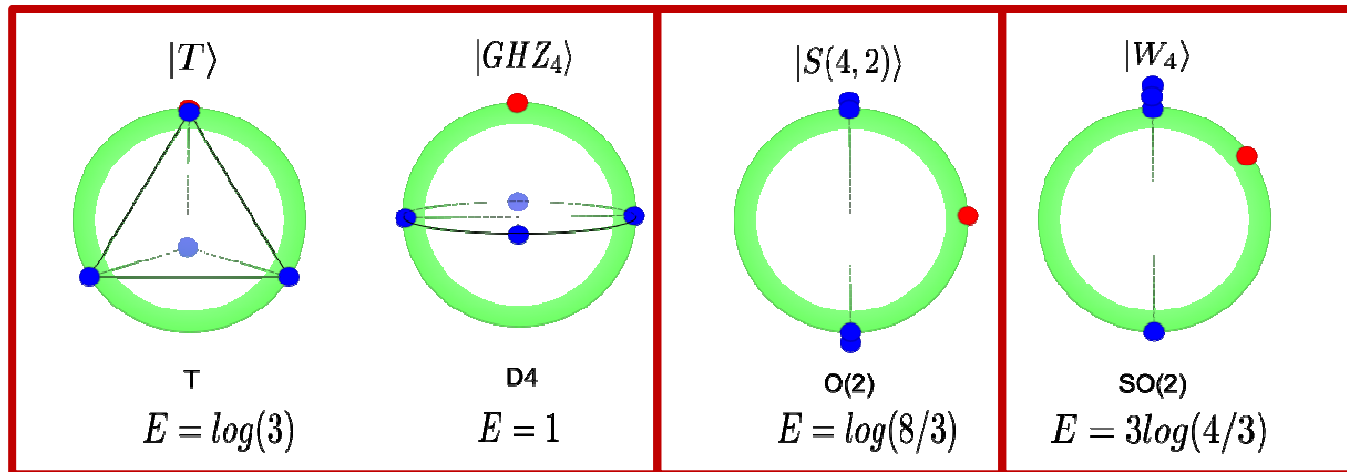

- Multiplicity of points cannot change under SLOCC

LU Symmetry and Entanglement 'types'

E.g. $n=4$

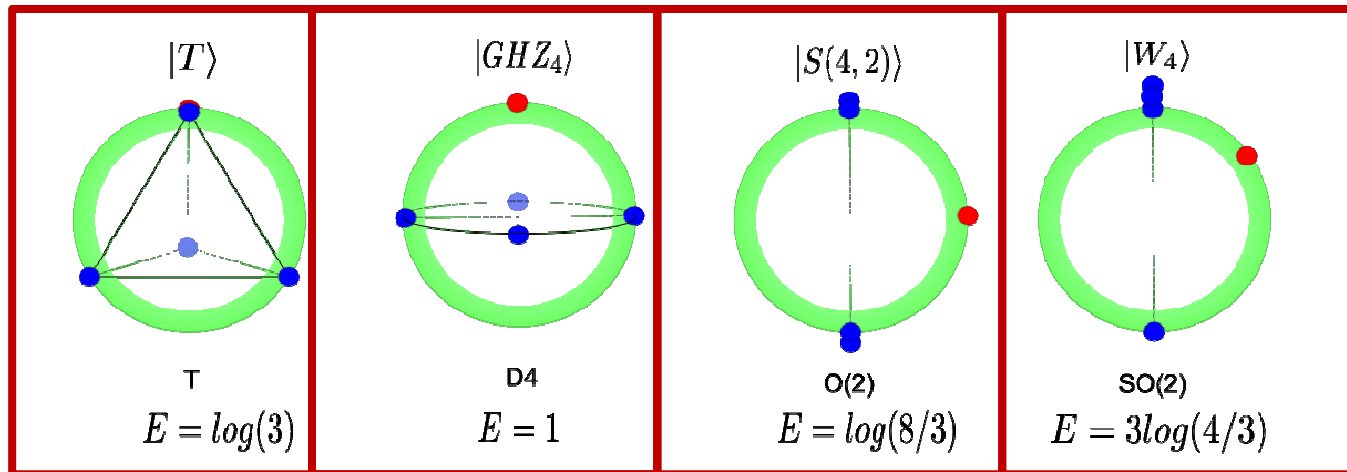

- Multiplicity of points cannot change under SLOCC
- Minimum size of product state decomposition (Schmidt number r) cannot change*

$$|\varphi\rangle = \sum_{i=1}^r |\phi_i^1\rangle |\phi_i^2\rangle \dots |\phi_i^n\rangle \quad E_G \leq \log(r) \quad \begin{aligned} r(|GHZ\rangle) &= 2 \\ r(|T\rangle) &\geq 3 \end{aligned}$$

[^]T. Bastin, S. Krins, P. Mathonet, M. Godefroid, L. Lamata and E. Solano, PRL 103, 070503 (2009)

*Dur, Vidal, Cirac, PRA 62, 062314 (2000)

Summary

Local Unitary (LU)  Rotation of sphere

$$U \otimes U \dots \otimes U |\varphi\rangle = \frac{e^{i\alpha}}{\sqrt{K}} \sum_{Perm} U |\eta_1\rangle U |\eta_2\rangle \dots U |\eta_n\rangle$$

Symmetries under LU are symmetries of points under SO(3)

- Visualise the geometric measure of entanglement
- LU symmetries imply equivalence of different entanglement measures
- Different symmetries (LU)  different entanglement 'types' (w.r.t. SLOCC)

Comparison to Spinor BEC

n spin $\frac{1}{2}$

single spin $s=n/2$

Geometric measure of entanglement



Distance from *spin coherent state*

LU symmetry and equality of entanglement measures



Exact condition for *inert states*

Different symmetries, different entanglement types



Different symmetries, *different phases*

Comparison to Spinor BEC

E.g. $S=2$

R. Barnett, A. Turner and E. Demler, PRL 97, 180412 (2007)

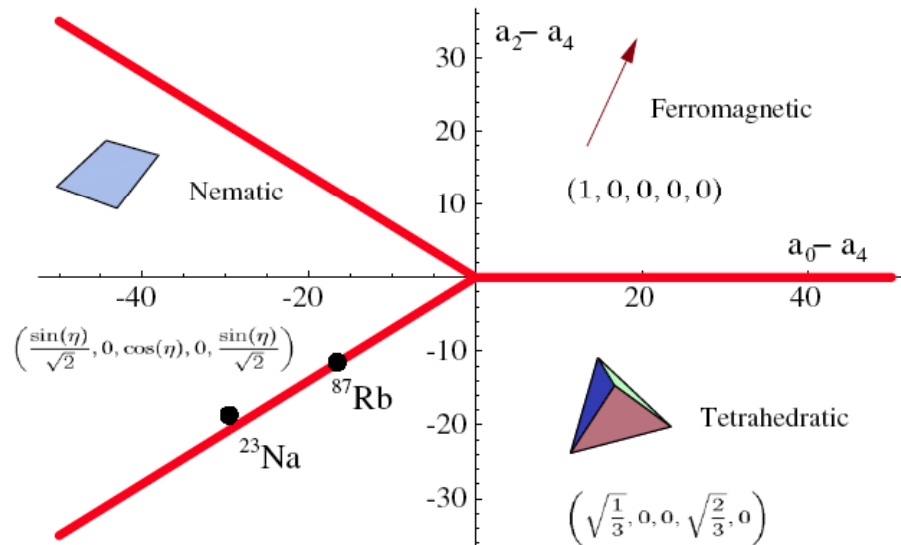

Phase diagram for spin 2 BEC in single optical trap
(Fig taken from PRL 97, 180412)

Comparison to Spinor BEC

E.g. $S=2$

R. Barnett, A. Turner and E. Demler, PRL 97, 180412 (2007)

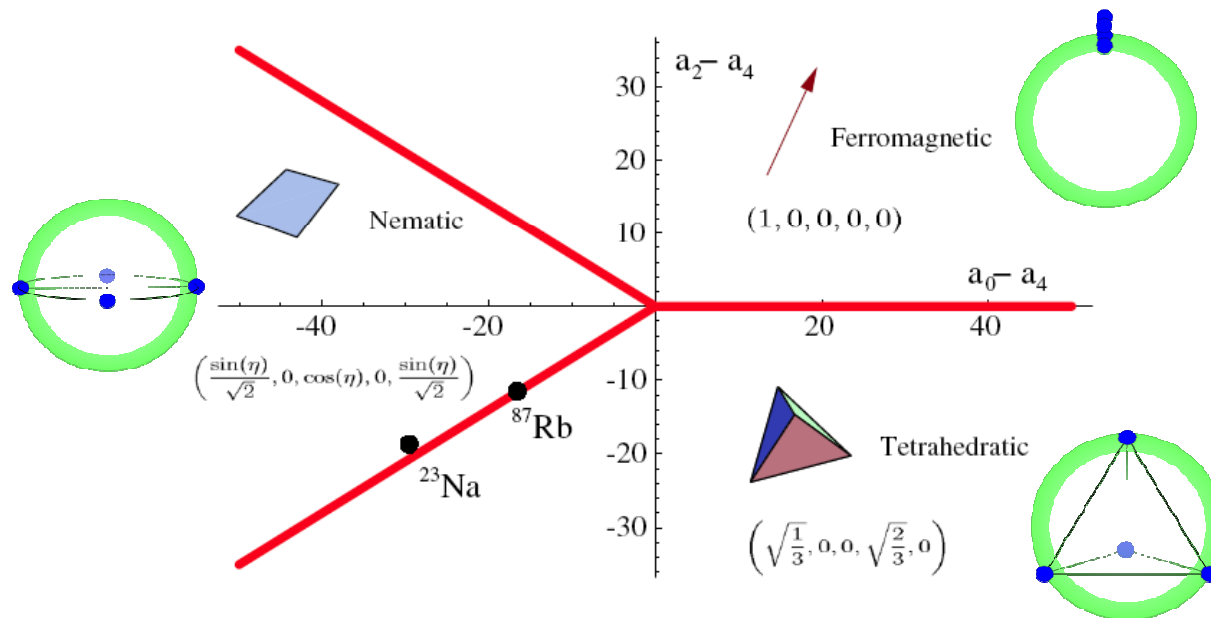

Phase diagram for spin 2 BEC in single optical trap
(Fig taken from PRL 97, 180412)

Comparison to Spinor BEC

E.g. $S=2$

R. Barnett, A. Turner and E. Demler, PRL 97, 180412 (2007)

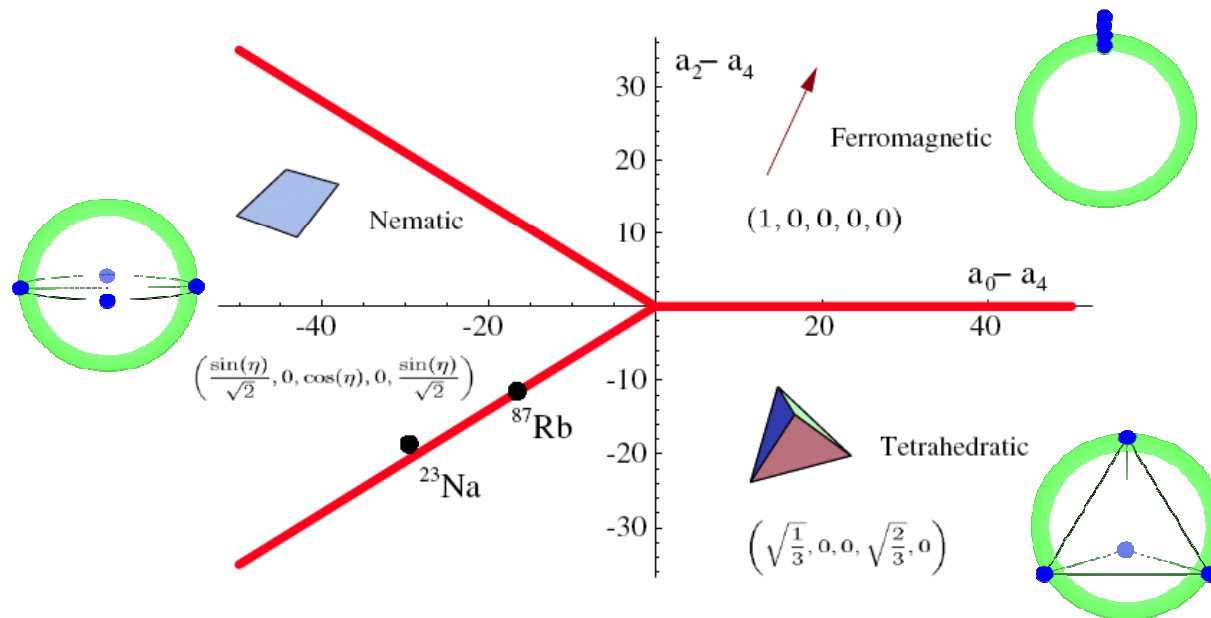

Phase diagram for spin 2 BEC in single optical trap
(Fig taken from PRL 97, 180412)

- CAUTION: *not* entanglement if single system

Comparison to Spinor BEC

E.g. $S=2$

R. Barnett, A. Turner and E. Demler, PRL 97, 180412 (2007)

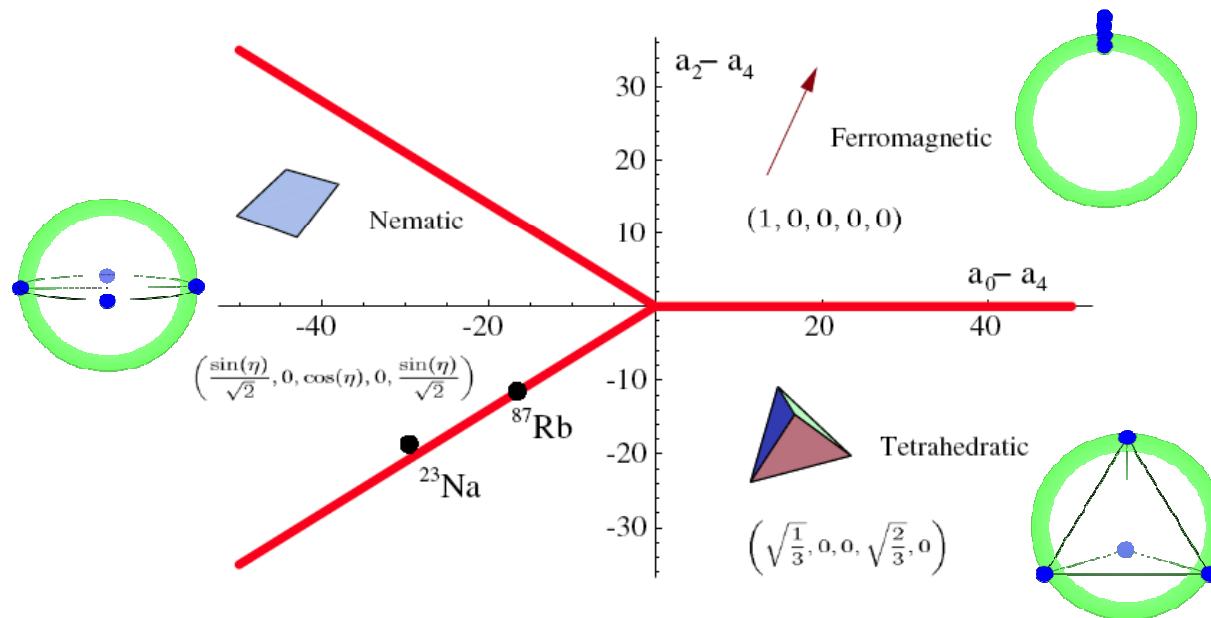

Phase diagram for spin 2 BEC in single optical trap
(Fig taken from PRL 97, 180412)

- CAUTION: *not* entanglement if single system ... unless it is ☺ (if made up from spin $\frac{1}{2}$)

Conclusions

- Relation between LU symmetry and entanglement
 - Geometric measure of entanglement
 - Equivalence of measures
 - LU symmetries vs. 'types' of entanglement
- Intriguing mirrors in spinor BEC
- MORE?
 - Generalisation?
 - Entanglement as 'order parameter' for symmetry breaking?
 - Entanglement phase transitions?